

# IONIZER USER MANUAL

---

## Model 2K10

Alternative Room Ionization System

Version 1.1





# IONIZER USER MANUAL

## Model 2K10

Alternative Room Ionization System

Version 1.1

# Contents

---

<b>1. Introduction</b> .....	4
<b>2. Ionization and Application</b> .....	5
A. Ionization Theory	
B. Cleanroom Contamination Application	
C. ESD Control Application	
D. AC Ionization and Industrial Application	
<b>3. Application Guide</b> .....	7
A. Basic ESD Control	
B. Ionization for CDM/CBE Control	
<b>4. Cautions and Personal Safety</b> .....	8
A. Cautions	
B. Personal Safety	
<b>5. Technical Specification</b> .....	9
<b>6. Drawings</b> .....	10
<b>7. Setup and Operation</b> .....	10
A. Introduction	
B. Descriptions for Model 2400	
C. Descriptions for Model 6380	
D. Installation	
E. Powering the System	
F. Output Settings	
<b>8. Maintenance</b> .....	19
<b>9. Warranty and Services</b> .....	20

# Introduction 1

---

Core Insight, Inc. is an ionization system manufacturer and supplier to ESD and contamination control application. Core Insight, Inc. also provides ESD Test and Measurement equipment, Professional Static Auditing Kits, EMI Noise Filters and EOS/ESD Technical Services such as ESD Training, Process Assessment, ESD Control Program Development and Product Qualification Testing per ANSI/ESD Standards.

Core Insight, Inc. is a leading company for ESD and contamination control in the fields of semiconductors, flat panel displays, automotive, and general electronic manufacturing industries. Core Insight, Inc. was founded in 2003 and business partnership with ProStat Corporation, ON Filter, Monroe Electronics, Electro-Tech Systems, and Dangelmayer Associates etc.

# 2 Ionization and Application

---

## A. Ionization Theory

Ionization solution has been used many years in electronic industry. Electrical ionization technology is most common design for many applications. Some ionizers designed for ESD application and some of them are contamination control in high technology manufacturing environment. Both are different purpose and may not work in both applications. Follows are the brief summary of differences and user guide for each applications.

## B. Cleanroom Contamination Application

Electric field is one of strong force to attract particles on wafer, glass panel, printed circuit board and other insulator materials. To minimize this force, room ionization is the best solution in high technology and other cleanroom environment.

Pulsed DC ionization technology is the well known solution over many years to minimized air borne particle attraction in cleanroom environment. Using with laminar flow, generated ions can move long distance and wide coverage areas. This will significantly reduce the force between particles and sensitive devices such as wafer, flat panel display and medical items. In results, room ionization improves product yields and less losses.

## C. ESD Control Application

Voltage (or Potential) difference is the reason why ESD event occurs and lead to device damage. Ionizer makes this voltage difference to the same or minimize the level between objects to avoid ESD damage or make it happen at the safe level.

Steady-State DC ionizer is provide high ion current to objects and maintain low peak (or offset) voltage on it. This makes minimize ESD risk in production and suitable for CDM ESD control in control program.

## 2 Ionization and Application

---

CoreStat® Self-Balanced Ionizers developed based on steady-state DC technology and upgraded the ground isolated power circuit design. It can maintain low peak (or offset) voltage performance by intrinsic balancing circuit design with longer maintenance cycle time. It does not require calibration or adjust to maintain low offset voltage and it needs to cleaning emitter points for decay performance.

### D. AC Ionizations and Application

Core Insight, Inc. provides several AC ionization systems. Conventional AC ionizer for industrial applications such as roll to roll or winding & unwinding of paper, film and non-ESD sensitive areas. Bipolar Pulsed AC ionizer is output parameter adjustable technology to meet each application requirements. High Frequency AC has adopt piezo crystal power supply for neutralize charge on insulative materials in small package. AC ionizer generates more Ozone than DC in the environment and may cause of side effects in sensitive device handling areas.

All ionizers performed and tested per ANSI/ESD STM3.1 and other documents such as ANSI/ESD SP3.3, ANSI/ESD SP3.4 and ANSI/ESD SP3.5.

For more detail information about ionizer solution and technical support needed, please feel free to contact our sales representative at [sales@coreinsight.co.kr](mailto:sales@coreinsight.co.kr) or your local contacts.

# 3 Application Guide

---

## A. Basic ESD Control

Basic ESD control is mandatory required to electronic industry. It follows simple principle to make equipotential between ESD sensitive items. Personal grounding, ESD safe worksurfaces and ESD safe packaging materials are the key control items in ESD protected area.

## B. Ionization for CDM/CBE Controls

Due to automated process in high technology manufacturing environment, Charged Device Model (CDM) or CDM-like ESD damage becoming a major portion of device failures. Industry Council agreed to reduction of CDM protection target level down to 125V level and will impact basic level of ESD control program and organization. Not only CDM, but also Charge Board Event (CBE) like ESD issues are increasing due to device complexity and stored large amount of charge on printed circuit board.

Strategic guidance has been proposed by the EOS/ESD Association. Lowering device charged voltage level and increasing resistance of contact materials are the key strategic elements to prevent or minimize ESD damage.

ANSI/ESD S20.20 standard requires maximum allowable field strength is 125 V/inch for 200 V CDM device. Low peak (or offset) voltage of ionizer performance is important for ESD sensitive device control and control program per S20.20 based.

Core Insight, Inc. provides intrinsic low peak balancing Steady-State DC Ionizers for CDM ESD control with less maintenance.

For more detail information about ionizer solution and technical support needed, please feel free to contact our sales representative at [sales@coreinsight.co.kr](mailto:sales@coreinsight.co.kr) or your local contacts.



# Cautions and Personal Safety 4

---

## A. Cautions

Use of proper input voltage to avoid damaging the system.

Verify the cabling and its connection between controller, junction box and individual ceiling emitters before turn on the system.

Disconnection cable from ceiling emitters will damage the system.

Do not clean emitter point while the system is powered. This may result of additional contamination issue and possible electrical shock.

Do not open the system by un-authorized personnel while the system is powered. This will void the warranty and may result in additional cost.

## B. Personal Safety

Before performing any maintenance on emitter points, it is highly recommended turn-off the system. Allow few minutes for high voltage power supplies to discharge.

# 5 Technical Specification

---

Input Voltage	24 VDC, 5.7 Watt Max.
Output Voltage	±13kV DC, 100V Resolution Adjustment
Ion Emission	Pulsed DC Technology
Display	3 digit LED Display
Control	Voltage, On/Off Time by Model 5711R
Timing	On Time: 0.1 - 99.9 sec / 0.1 sec resolution
Communication	RJ-45 modular terminal
Emitter Point	Tungsten 99.99%. All emitter points replaceable
Alarm	LED Alarms operates voltage feedback monitoring, power and sync failures
Output Monitoring	Relay Output
Material	Enclosure: ABS, Pipe: Polycarbonate
Operating Environment	Temperature: 15~35°C Humidity: 30~60% RH
Dimensions (mm)	86H x 85D x 1000, 1500, 1700 and 2000L
Warranty	1 year limited warranty

# Drawing 6

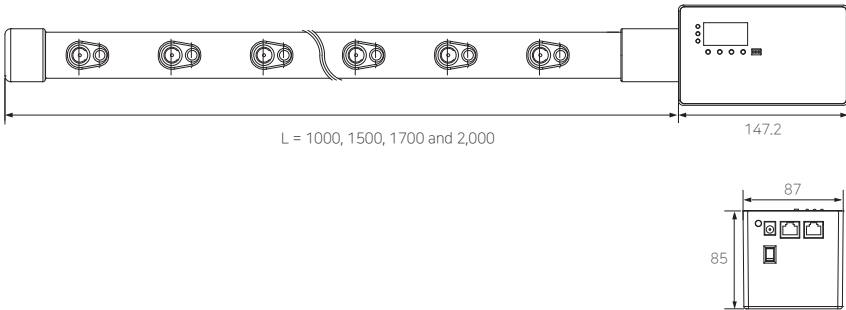

## Setup and Operation 7

### A. Introduction

Model 2K10 AirStat® alternative room ionization system is designed to control electrostatic fields in flat panel display industry to improve ESD damage and particle contamination control in relatively big room environment. Model 2K10 alternative room ionization system using pulsed DC technology with symmetrical dual bar combination. All output parameters can adjustable through Model 5711R remote controller.

# 7 Setup and Operation

## B. Description of Model 2K10 alternative room ionization system

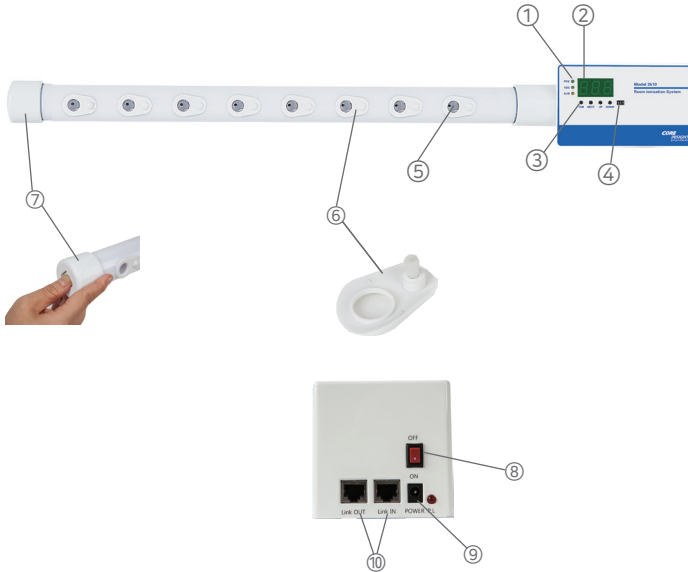

- ① LED: Indication of polarity operation and alarm
- ② 3 digit LED display for output voltage and on/off time
- ③ Switch for output parameter adjustment
- ④ DIP Switch for master/slave mode selection
- ⑤ Tungsten emitter point
- ⑥ Cleaning brush
- ⑦ Manual push switch for cleaning emitter point
- ⑧ Power Switch and Red LED will turn on
- ⑨ DC Adapter Receiver
- ⑩ RJ-45 Communication Port between master and slave

## 7 Setup and Operation

### C. Installation

Determine locations of alternative room ionizers and mount polycarbonate bracket on profile in work environment. Space between dual bar would be sufficient within 2 meters and possible to use maximum 3 meters distance.

Recommended communication cable is CAT-5 or better ethernet cable and maximum length is 10 meters between master and slave unit. Model 2K10 dual bar system install over 1 meter distance from the floor or stage and facing each other or adjust angle to middle. Due to pulsed DC operation, both side of bottom of bars will be fast discharge area and center of area will be slowest discharge area.

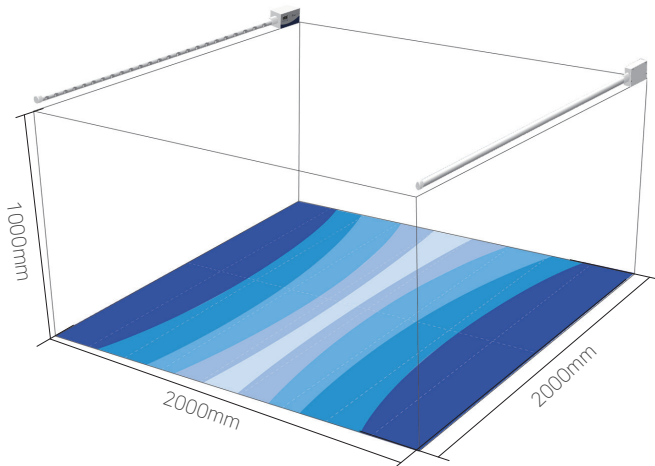

# 7 Setup and Operation

Communication cable must be tested and verified during installation at each desired locations. All cables are test for open, short and color matching. From master unit to slave unit or daisy-chained wiring should be all straight connection not cross wiring.

Following test result is an example of discharge data and result will vary due to laminar flow and environmental condition differences. Rainbow image at bottom is a concept of alternative room ionization.

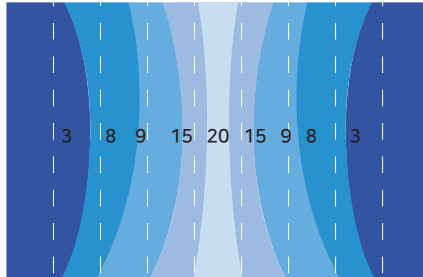

ANSI/ESD SP3.5 - Alternative Room Ionization Test Method  
Measurement unit - second

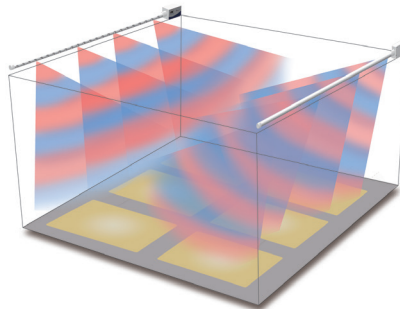

## Cautions

Do not connect or disconnect room ionizers when powered.  
Turn on when all ionizers installed properly and cable connected between master and slave units.

## 7 Setup and Operation

### E. Powering the System

Once all systems in place and connected properly, turning on the master unit. Then slave unit automatically powered. Be remind that slave unit power switch must be on position.

### F. Output Settings

Once alternative room ionization system is powered, it will operate at the factory default mode. All output paramters can be set differently to satisfy different operating environments or needs within the same area.

Following sections described functions and features of alternative room ionization system on LED display. User can select high voltage on time for both polarity, high voltage output levels by 0.1kV resolution and alarm level settings.

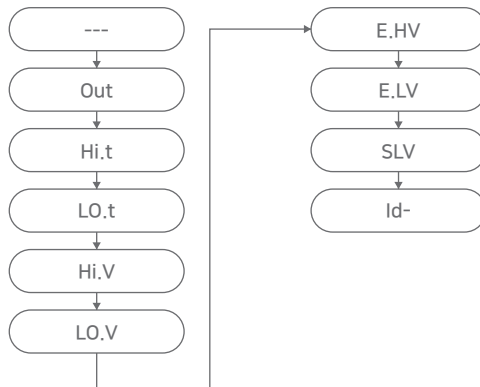



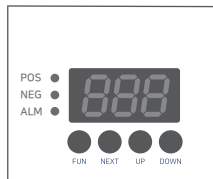

# 7 Setup and Operation

To start communicating press FUN button on master unit controller and adjustable output parameters. LED will display as below and all parameters can be adjustable by UP/DOWN. Once user changed any parameter, press FUN to store value in memory and make changed value operational.



## 1) Controller Operation

User can adjust parameters from master unit controller.

-  Press FUN to parameter modes and save value
-  Press NEXT to move next parameter mode
-  Press UP to increase selected parameter value
-  Press DOWN to decrease selected parameter value

\*If user did not press FUN after change parameters, adjusted value will not store and back to previous set value.



## 7 Setup and Operation

### 2) Output On/Off

Press FUN and OUT parameter will display.

On is factory default set for initial enable mode. Press UP/DOWN to change on or off. Press FUN to store this set.



### 3) High Voltage On Time

Press FUN and NEXT (1<sup>time</sup>). HI.t will display and positive output time.

3.5 sec is factory default set value. Press UP/Down or type numeric value up to 99.9 seconds maximum. Press FUN to store this set value.



Press FUN and NEXT (2<sup>times</sup>). LO.t will display and negative output time.

3.5 sec is factory default set value. Press UP/DOWN or type numeric value up to 99.9 seconds maximum. Press FUN to store this set value.



### 4) Output Voltage Adjustment

Press FUN and NEXT (3<sup>times</sup>). HI.V will display and positive high voltage level.

7.4 kV is factory default set value. Press UP/Down or type numeric value up to 13.0 kV maximum. Press FUN to store this set value.



Press FUN and NEXT (4<sup>times</sup>). LO.V will display and negative high voltage level. 6.7 kV is factory default set value. Press UP/DOWN or type numeric value up to 13.0 kV maximum. Press FUN to store this set value.



# 7 Setup and Operation

## 5) Alarm

Press FUN and NEXT(5 times). E.HV will display and positive alarm level. 0.0 kV is factory default set value. Press UP/DOWN or type numeric value preferred output margin value. Press FUN to store this set value.



Press FUN and NEXT (6 times). E.LV will display and negative alarm level. 0.0 kV is factory default set value. Press UP/DOWN or type numeric value preferred output margin value. Press FUN to store this set value.



## 6) Master/Slave Polarity Control

Press FUN and NEXT (7 times). SLV will display. This mode is same polarity or different polarity output selection for special application. Off is factory default set as different polarity mode. Press UP/DOWN to change output polarity. Inv is different polarity output selection and non is same polarity operation mode.



\*It is highly recommend that user do not change this setting.

## 7) ID Delete and Change

If user wants to change address ID, Press FUN and NEXT (8 times). Id- will display. Press UP/DOWN to adjust address ID. Press FUN to store.



## 7 Setup and Operation

---

# 8 Maintenance

---

## Warning

There are no user-serviceable parts inside the controller or ionizer. Any unauthorized service will void the warranty and may result in additional repair charge.

## General Maintenance Information

Emitter point maintenance ensures continued performance of room ionization system. Dirt or erosion to emitter points can be caused by a number of environmental factors, including airborne molecular contamination issue.

Before cleaning or removing emitter points, the room ionization system must be powered down by turn off the switch or unplug DC adapter.

### Step 1. Recommended Cleaning Materials:

- 1) Cleanroom-compatible cloth or wipe
- 2) Cleanroom approved swabs (foam is not recommended)
- 3) Cleaning solution of 50% isopropyl alcohol (IPA) and 50% deionized water mixture

## Caution

Do not clean emitter points while the unit is powered. Doing so may result in additional contamination and possible shock. After removing power from the emitter, allow few minutes for high voltage power supplies to discharge.

### Step 2. Cleaning the Emitter Points

Turn off the room ionization system. Clean the emitter points and areas around the emitter points, moisten a cleanroom-compatible swab or cleaning cloth in the IPA solution, or use cleaning solution from Core Insight. Gently rotate the swab or cleaning cloth around the emitter point. After cleaning allow the emitter points for dry out about 20 minutes. Turn on the system.

# Warranty and Service 9

---

Core Insight, Inc. provides a limited warranty for all ionizers. New products manufactured or sold by Core Insight, Inc. are guaranteed to be free from defects in material or workmanship for a period of defined schedules from the date of initial shipment. Core Insight, Inc.'s liability under its new product warranty is limited servicing (evaluating, repairing or replacement) any unit returned from customers that has not been subjected to misuse, neglect, lack of routine maintenance, repair, alteration or accident. In no event shall Core Insight, Inc. be liable for collateral or consequential damages.

To obtain service under this warranty, please contact sales representative at [sales@coreinsight.co.kr](mailto:sales@coreinsight.co.kr) or local contacts.





